

# TECHNODIAMANT

# TECHNODIAMANT

# TECHNODIAMANT

Established since 1968

### Comparison of grit systems

µm	DIN 848	FEPA-STANDARD	US-MESH	µm
1250	D 1100			1190
1000	D 900	D 1182	16/18	1000
800	D 700	D 1181	18/20	850
730	D 550	D 1001	20/25	710
500	D 450	D 852	25/30	600
400	D 350	D 851	30/35	500
315	D 280	D 711	35/40	425
250	D 220	D 602	40/45	355
200	D 180	D 601	45/50	300
160	D 140	D 501	50/60	250
125	D 110	D 427	60	212
100	D 90	D 356	60/70	180
80	D 65	D 252	80	150
63	D 55	D 251	80/100	125
50	D 45	D 213	100/120	106
40	D 35	D 181	120/140	90
32	D 25	D 151	140/170	75
25		D 126	170/200	63
		D 107	200/230	53
		D 91	230/270	45
		D 76	270/325	36
		D 64	325/400	
		D 54		
		D 46		

Technodiamant, established in Amsterdam in 1968, is a company dedicated to applications of diamond and CBN in all areas of technology and industry, supplying these products around the world.

Many industries use Technodiamant diamond and CBN wheels, diamond cutting tools, fly-cutting tools and engraving tools.

Technodiamant is also a leading supplier of diamond tools for the glass and optical industry.

**Technodiamant Almere B.V.**  
 Markerkant 13-11  
 1314 AL Almere  
 The Netherlands

Tel: +31(0)36-5343044 • Fax: +31(0)36-5342636  
 E-mail: info@technodiamant.nl  
 Internet: www.technodiamant.nl

**For U.S.A., Canada and Mexico:**  
 Technodiamant U.S.A. Inc.  
 200 Valley Road, Suite 107  
 Mt. Arlington, NJ 07856

Tel: +1-973-770 7220 • Fax +1-973-770 7225  
 E-mail: info@technodiamant.com  
 Internet: www.technodiamant.com

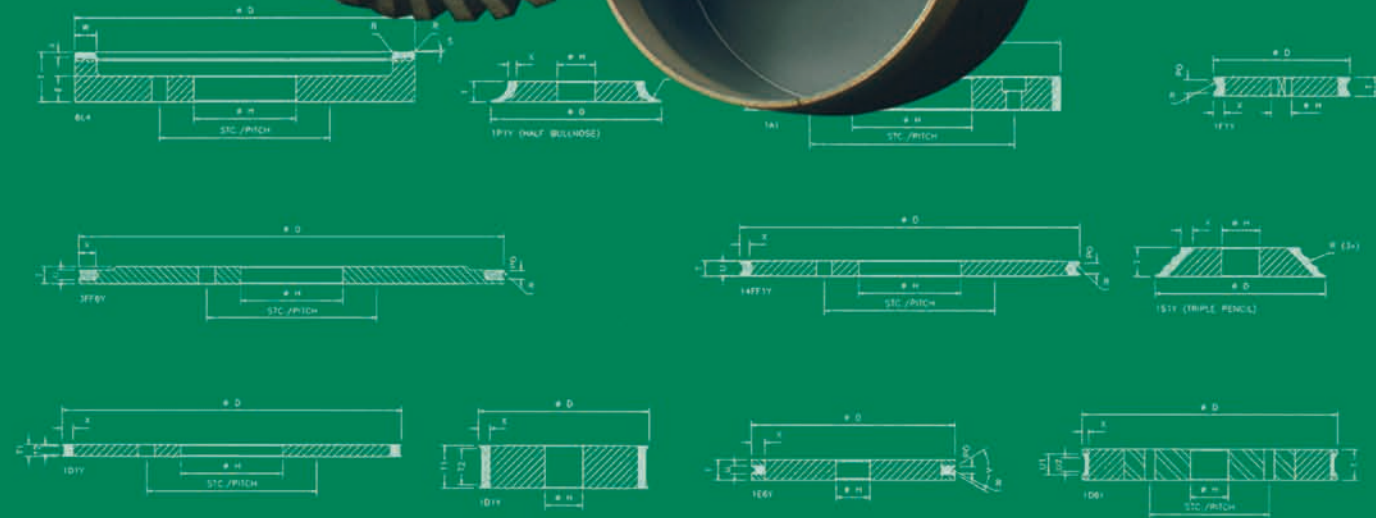
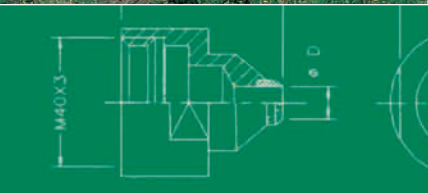
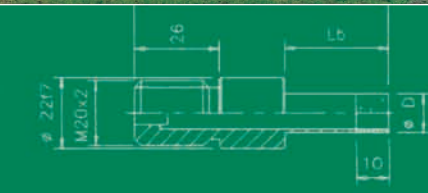
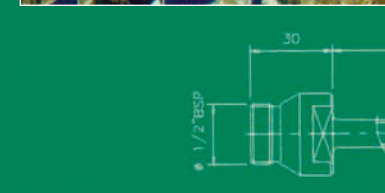
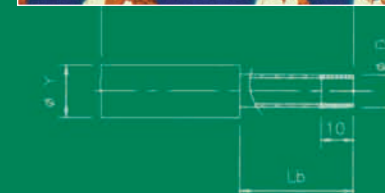
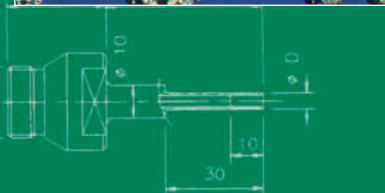
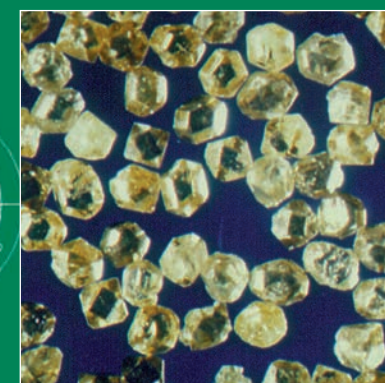
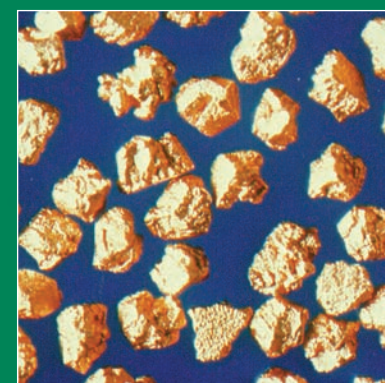
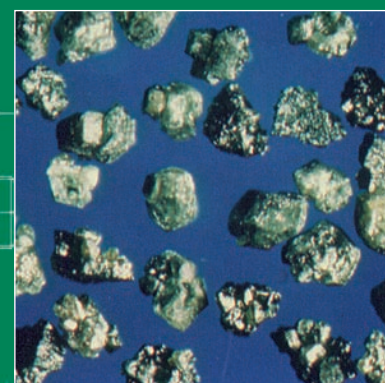
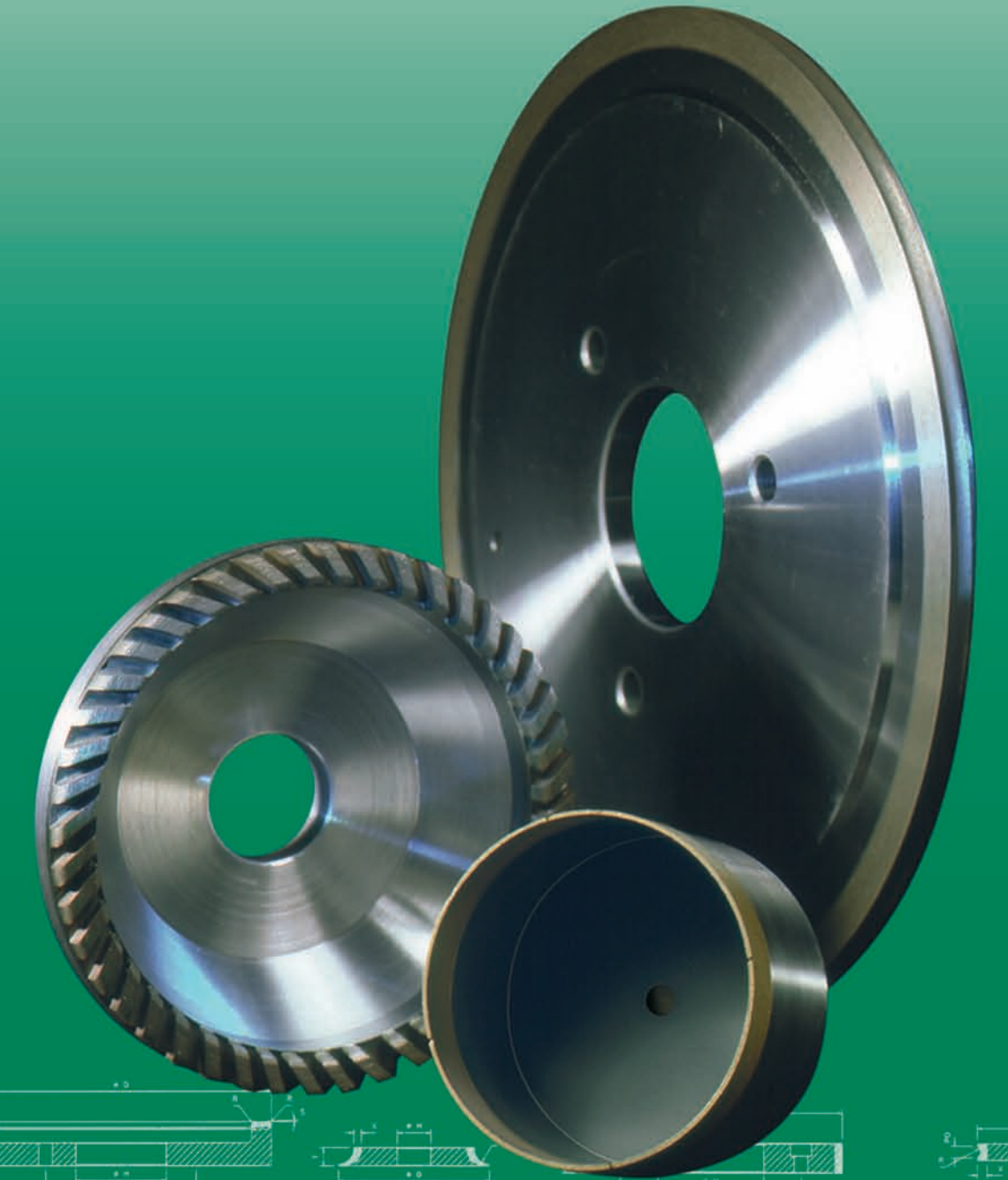

Diamond wheels-drills-countersinkers

# TECHNODIAMANT

Various tools from our product range

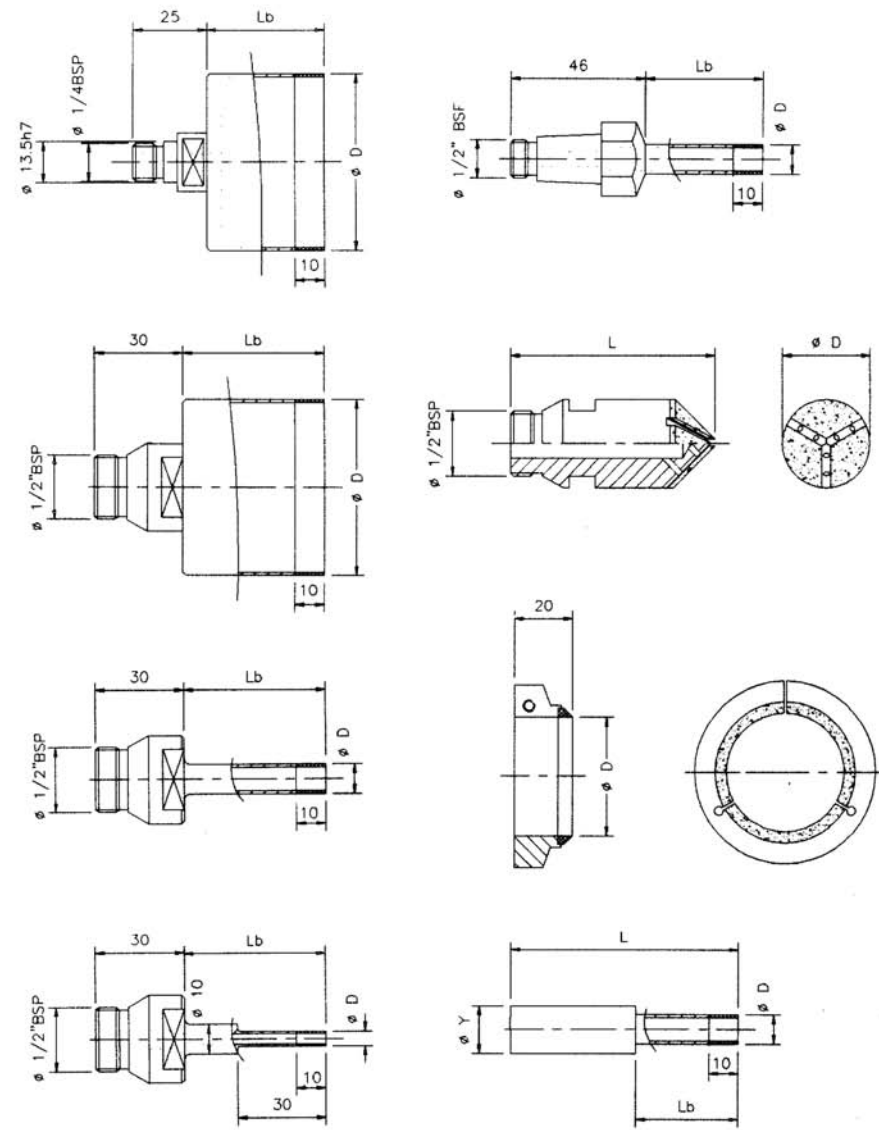

Sliding drills and countersinkers

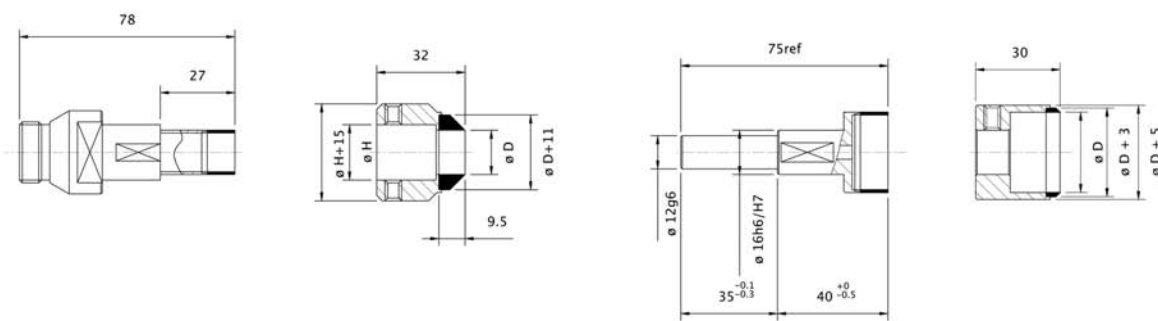

Diamond wheels-drills-countersinkers

# TECHNODIAMANT

## Diamond wheels-drills-countersinkers

For many years Technodiamant has been a leading manufacturer of diamond and CBN wheels and tools in The Netherlands. Many industries, including metalworking, electronic, plastic, ceramic and particularly the glass industry use Technodiamant products.

In its own factory Technodiamant produces metalbond diamond wheels, diamond drills and diamond countersinkers for the glass industry. These are used for the manufacture of corglass, mirrors, flat-glass and many other glass products. Diamond wheels with profiles in almost every requested shape can be supplied.

One of the outstanding advantages of Technodiamant glass drills and countersinkers is the stainless steel body.

Only first class diamond powders are used in Technodiamant products.

The drawings show the variety of the product range. Apart from the standard product range Technodiamant offers custom made products. For special applications, it can be necessary to refine the diamond grit size or to change the concentration of the diamond powder. When ordering, it is of importance to mention the application.

This enables Technodiamant to fulfil the needs of the customer.

Please contact Technodiamant for more information on standard products or custom designs.



# TECHNODIAMANT

Various wheels from our product range

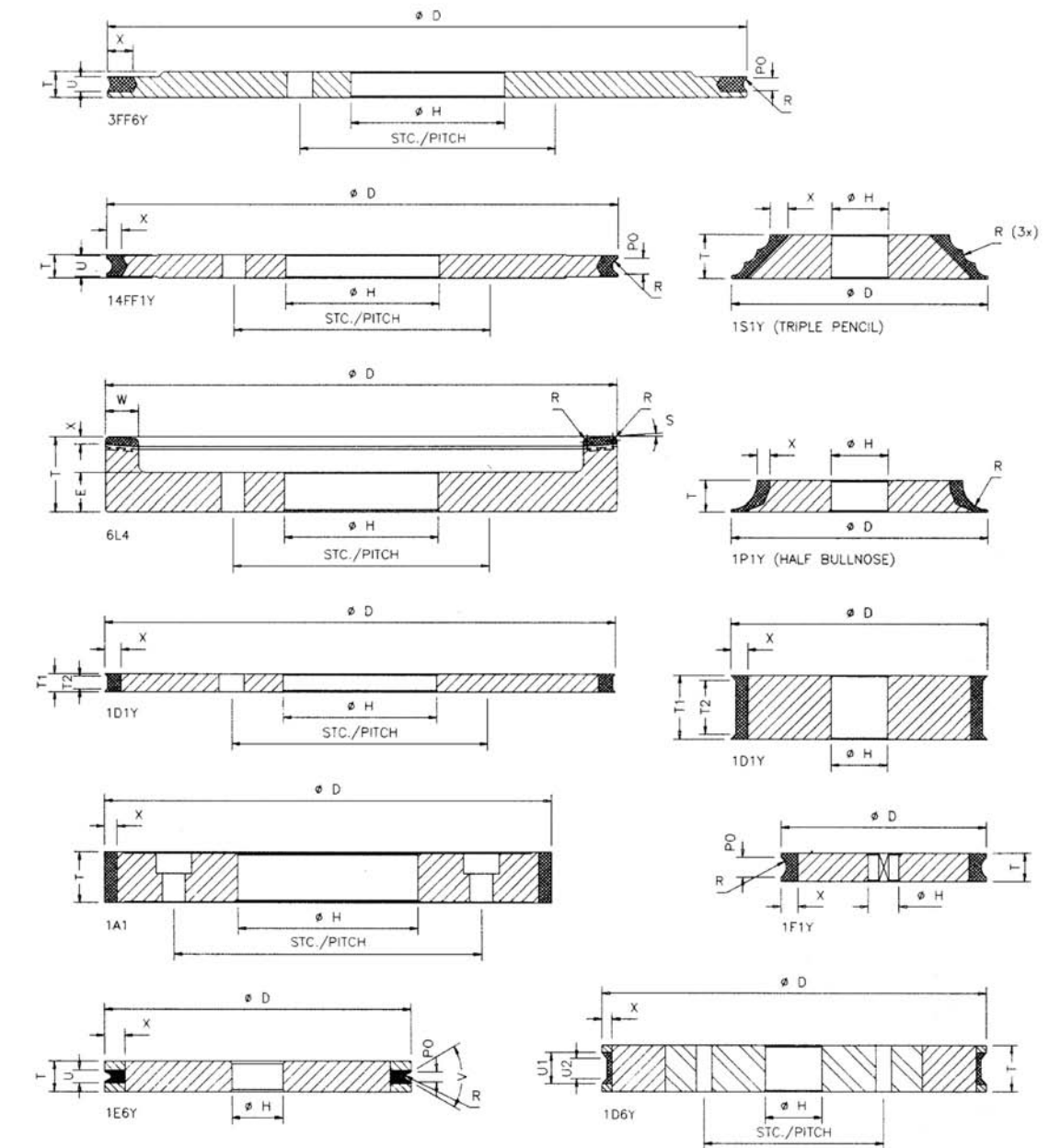

Milling tools for the optical industry

